

Plan View

10'

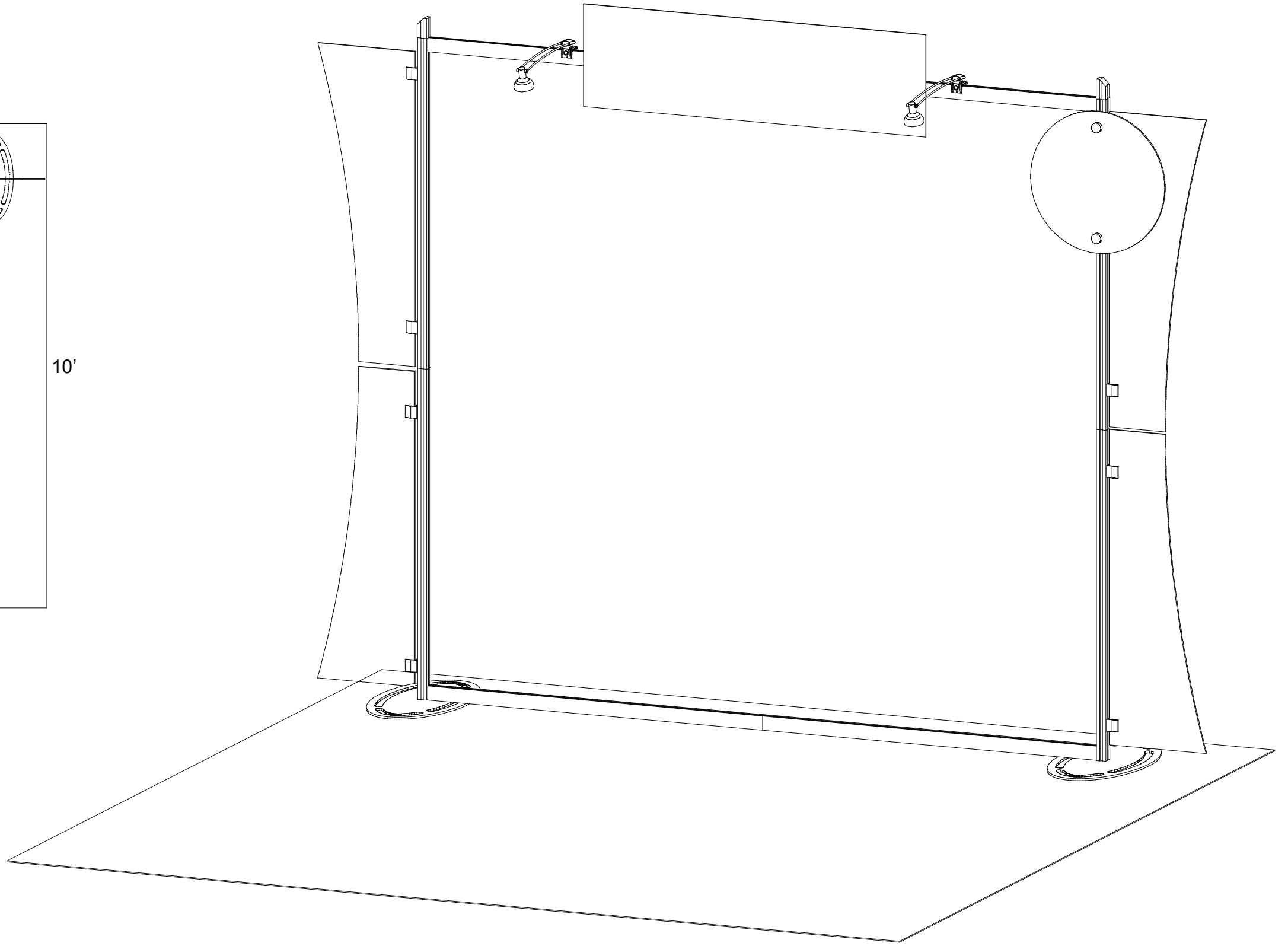

SETUP INSTRUCTIONS

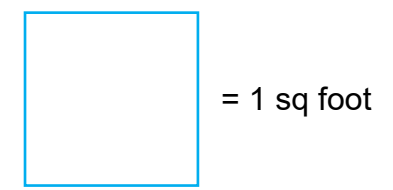
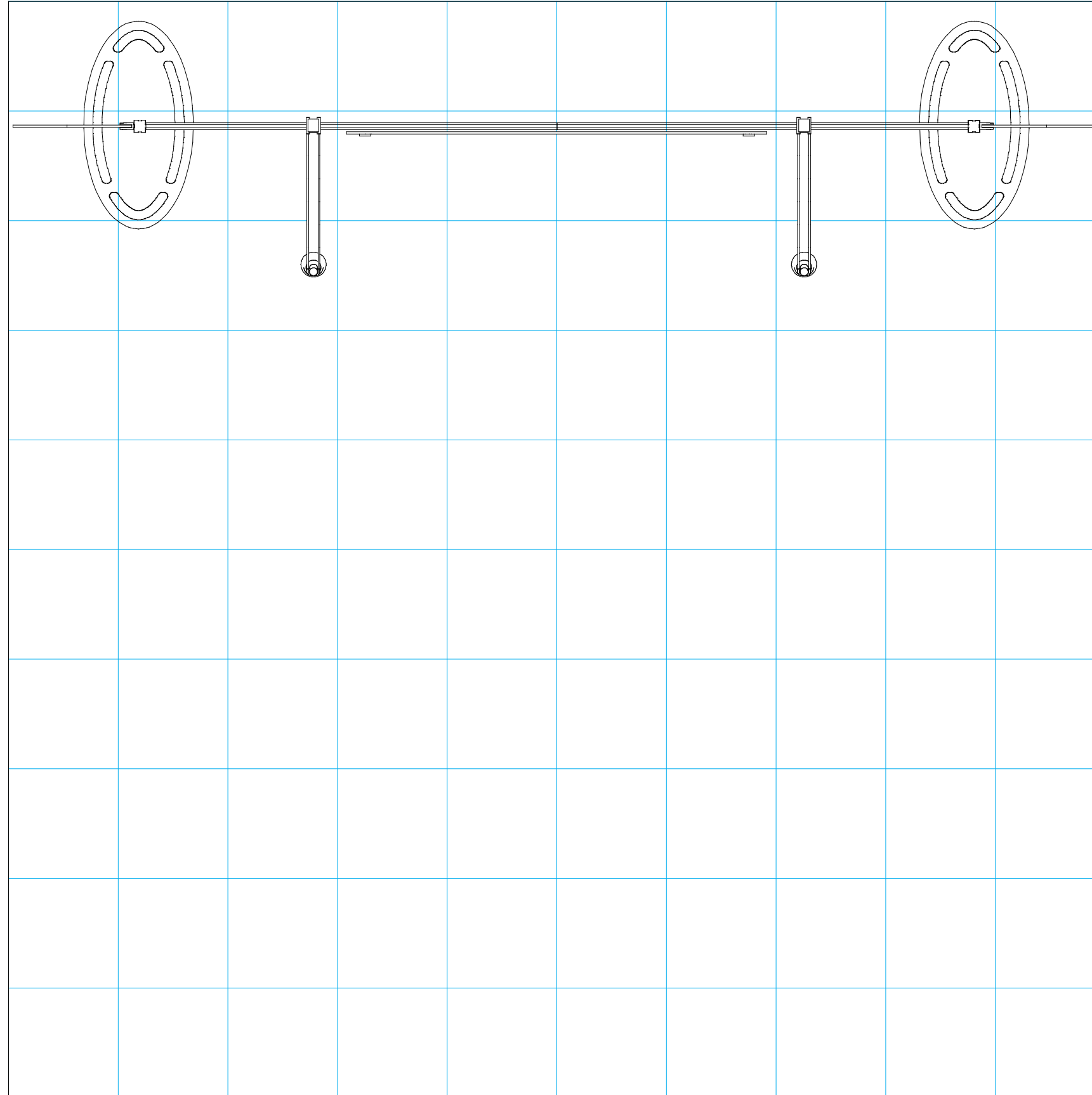

General Setup Instructions

- Read entire setup instruction manual prior to unpacking parts and pieces.
- The setup instructions are created specifically for this configuration.
- Setup instructions are laid out sequentially in steps, including exploded views with detailed explanation for assembly.

Cleaning & Packing

- For Cleaning Metal, Plex, & Laminate Parts: Use a **MILD NON-ABRASIVE** cleanser and soft cloth/paper towel to clean all surfaces.
- Keep exhibit components away from heat and prolonged sun exposure.
Heat and UV exposure will warp and fade components.
- Retain all provided Packing Materials. All provided packing materials are for ease of repacking & component protection.

Disassembly

- For loss prevention, tighten all set screws and locks during disassembly.



Hex Tool - Essential for Assembly

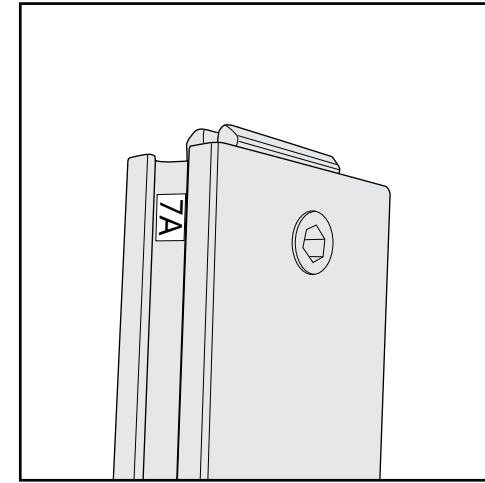

Part Identification - Numbering



Spline Connection



Base Plate & Extrusion Connection



Extrusion & Lock Connection



Engaged Lock



WARNING

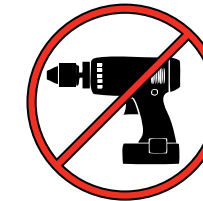

DO NOT USE POWER TOOLS

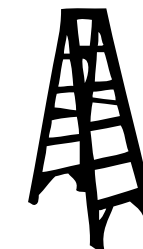

LADDERS OR LIFTS
MAY BE REQUIRED



ALL CONNECTIONS MUST
BE TIGHTLY SECURED



1) Mounting plate & wing nuts, in packed position.

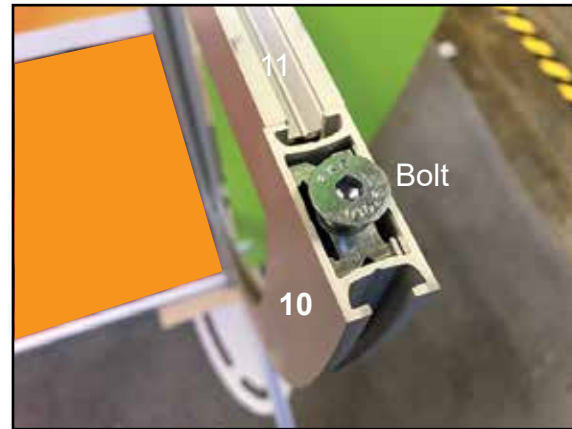

2) Mounting plate bolt in, packed position.

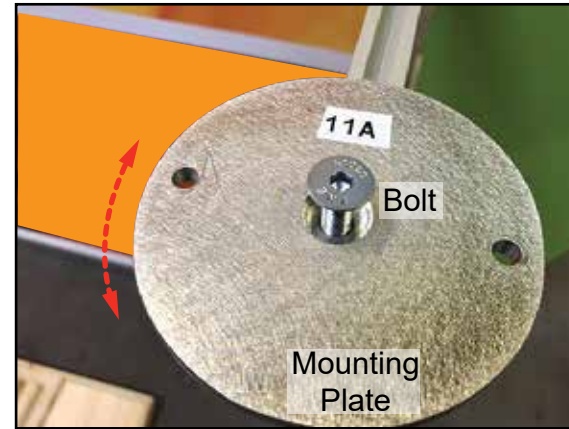

3) Place mounting plate onto [10] then tighten bolt, part way, allowing some rotation for final positioning.

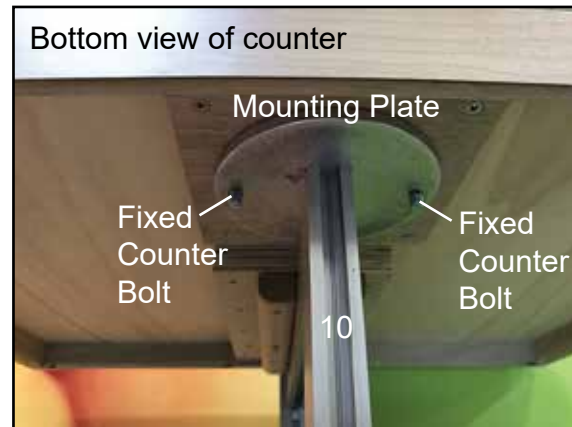

4) Place fixed counter bolts into mounting plate, then lift counter to re-tighten bolt.

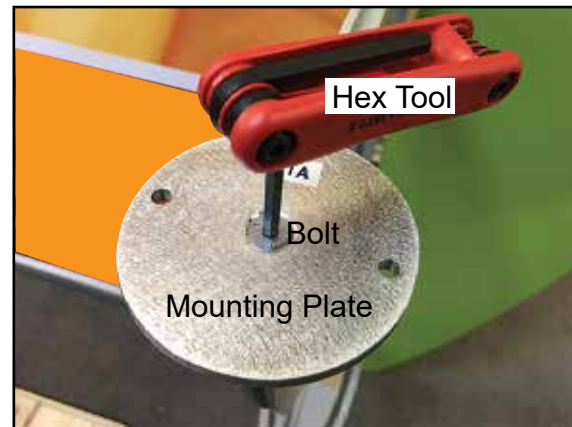

5) Tighten bolt, using hex tool, to secure.

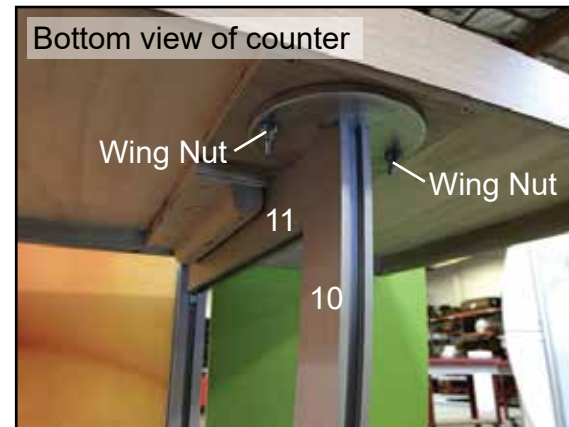

6) Place fixed counter bolts into mounting plate, then secure using wing nuts.

Completed Assembly



Counter Attachment

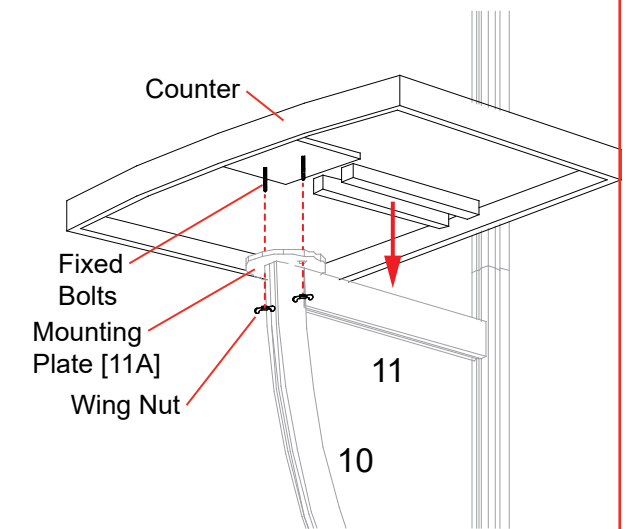

Attach mounting plate to curved extrusion [10], using bolt. Insert fixed bolts, located on underside of counter, into holes of flange plate. Secure with wing nuts.

Keep mounting plate [11A] and wing nuts attached to counter, when packing.

Keep bolt attached to [10], when packing.

Top View of Each Level

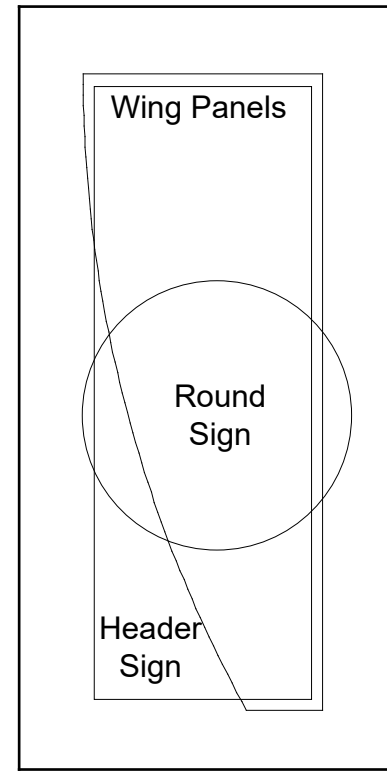

Level 1 (Bottom Level)

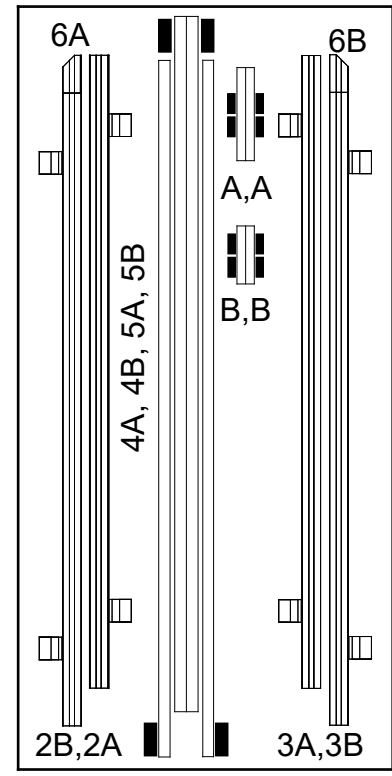

Level 2

Lights

Graphics

Setup Hardware
Base Plates

Item	Qty.	Description
1	2	Base Plate
2A,2B	1,1	42" S40 Vertical Extrusion w/ A10 Clamps
3A,3B	1,1	42" S40 Vertical Extrusion w/ A10 Clamps
4A,4B	1,1	45" Z45 Horizontal Extrusion
5A,5B	1,1	45" Z45 Horizontal Extrusion
6A,6B	1,1	2.5" S40 Angle-Cut Vertical

Steps:

- 1) Attach base plates [1] lower verticals [2A] and [3A], using bolts.
- 2) Connect verticals [2A to 2B] and [3A to 3B], using connection bars [B].
See [Straight Connection with Knobs](#) detail.
- 3) Connect horizontals [4A to 4B] and [5A to 5B], using connection bars [A].
See [Straight Connection with Knobs](#) detail.
- 4) Connect assemblies [2A/2B] and [3A/3B] with assemblies [4A/4B] and [5A/5B].
See [Corner Connection with Knob](#) detail.
- 5) Connect extrusions [6A to 2B] and [6B to 3B].
See [2.5" h Angle-Cut Vertical Attachment](#) detail.
- 6) Attach graphic to Velcro on back of assembled Backwall.

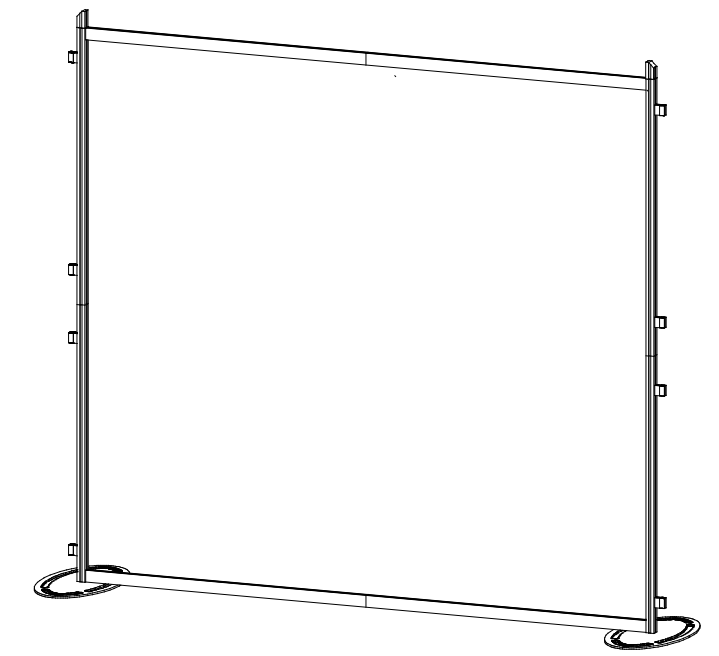

When Assembled

Keep extrusions [6A,6B] attached to [2B,3B].
Keep A10 clamps attached to [2A,2B,3A,3B].

★ **Corner Connection with Knob**



Turn knob clockwise to tighten lock.

Do not over tighten Knobs

◆ **Straight Connection with Knobs**

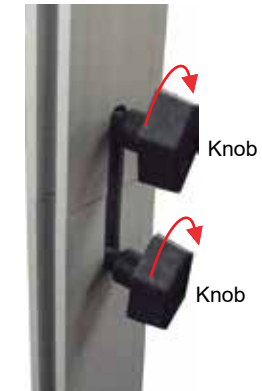

Slide connection bar between extrusions, then turn knobs clockwise to tighten lock.

Do not over tighten Knobs

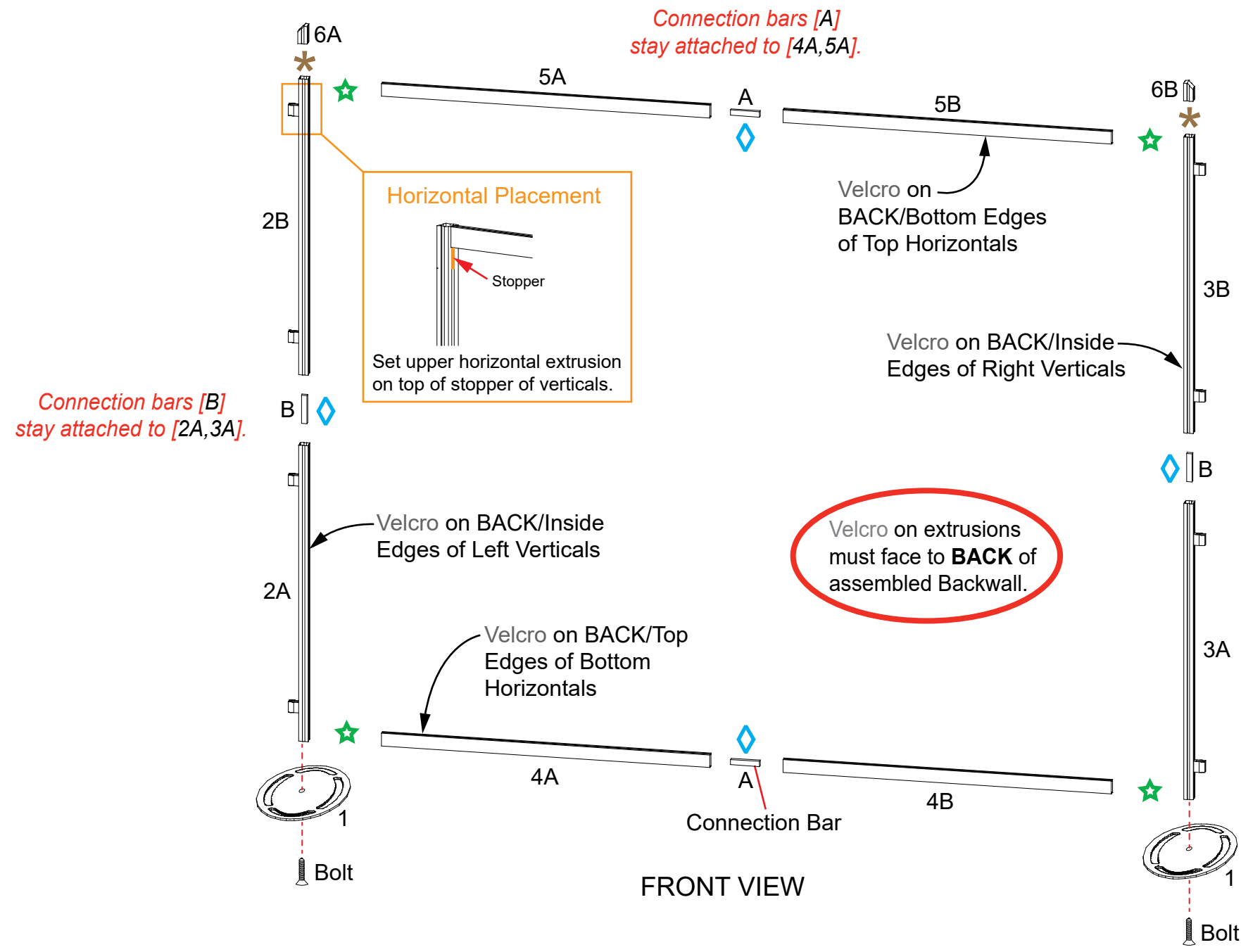

FRONT VIEW

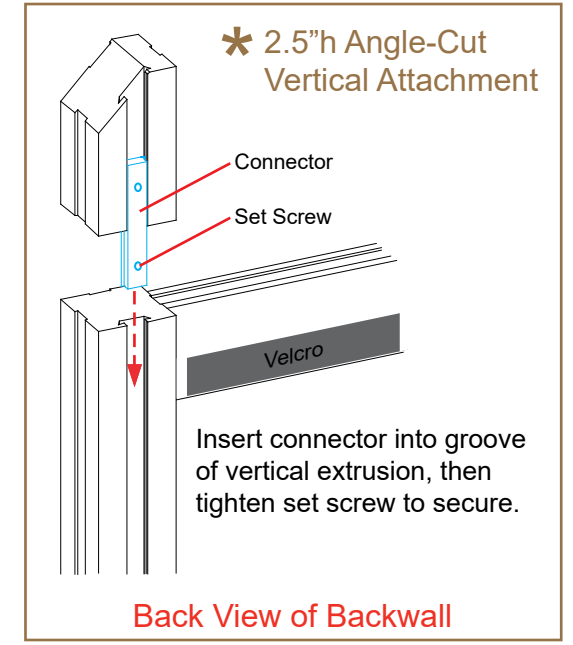

Back View of Backwall

Steps:

- 1) Connect lights to top horizontal extrusions [5A/5B]. See **Light Connection** detail.
- 2) Affix Header Graphic to top horizontals, using Velcro.
- 3) Attach wings to A10 clamps. See **Clamp Attachment** detail.
- 4) Attach sign to vertical extrusion [3B]. See **Sign Attachment** detail.

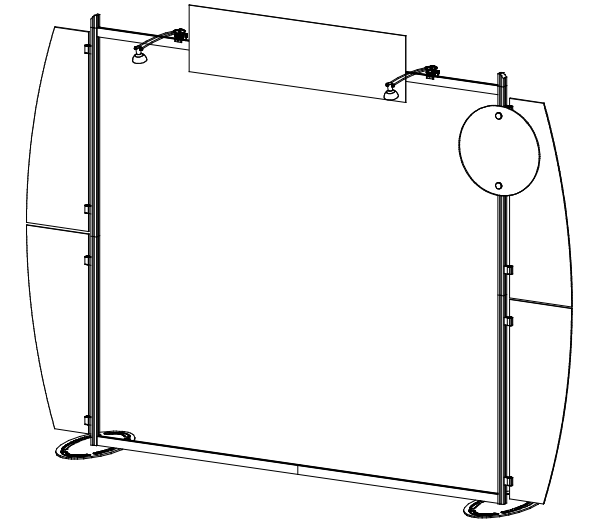

When assembled

Clamp Attachment

- 1) Slide connector of clamp into extrusion groove.
- 2) Tighten set screw when A10 is in desired location.
- 3) Insert wing into clamp.
- 4) Tighten knob on clamp to secure wing in place.

Keep A10 clamps attached to verticals.

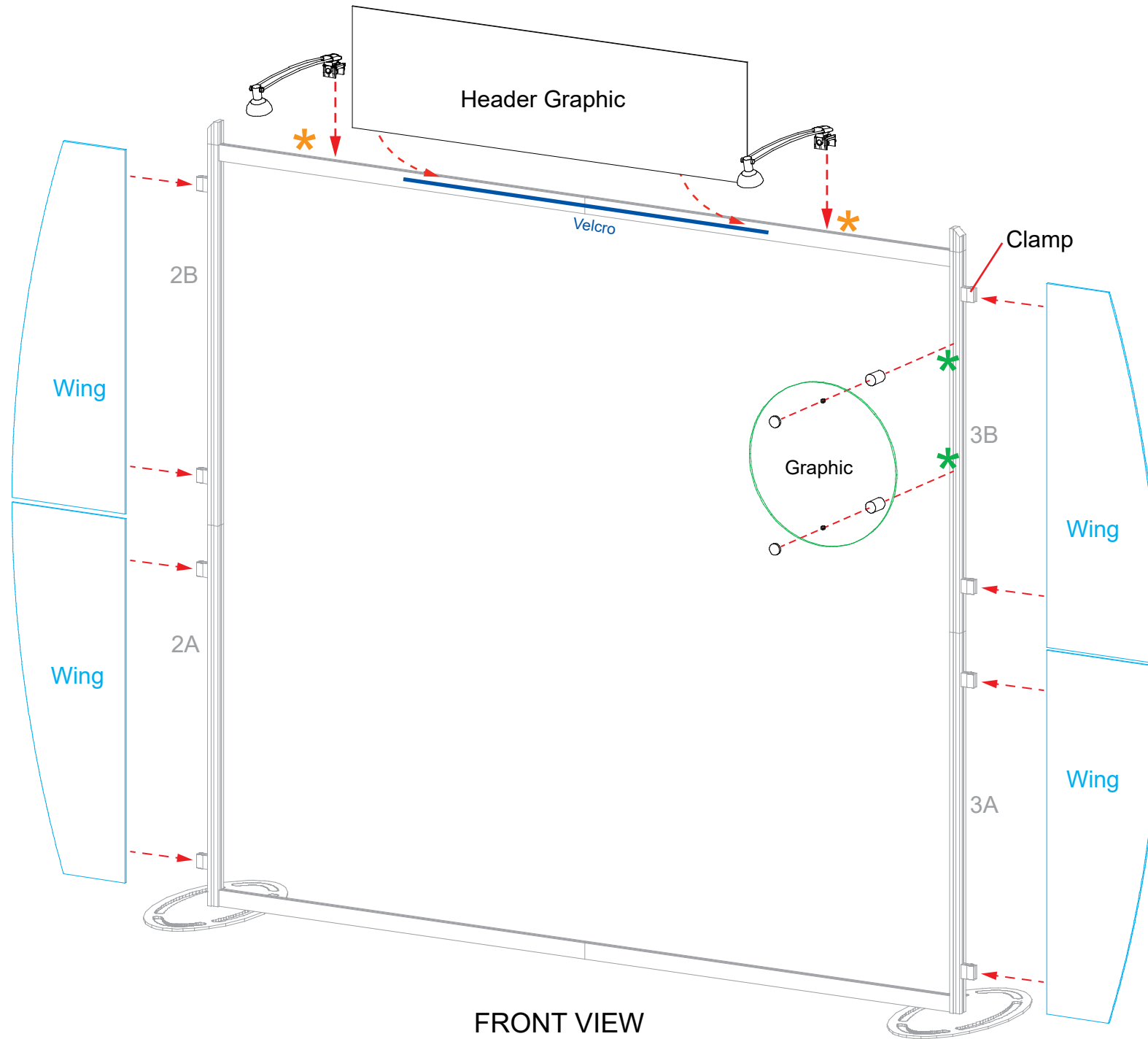

FRONT VIEW

*** Light Connection**

Slide light onto clip then lock clip into groove of horizontal extrusion.

*** Sign Attachment**

Slide connector into groove of extrusion. Tighten set screws to secure in place. Screw standoff into connector. Place sign between standoff and cap then tighten cap to secure sign.